

PLANT VIEW  
VISTA SUPERIOR

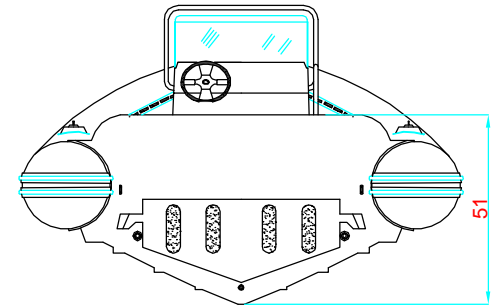

AFT VIEW  
VISTA TRASERA

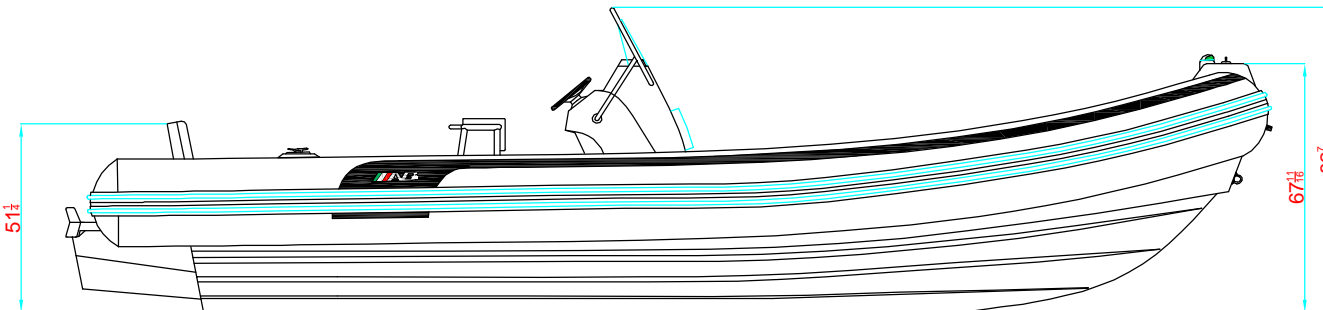

LONGITUDINAL PROFILE  
VISTA LATERAL

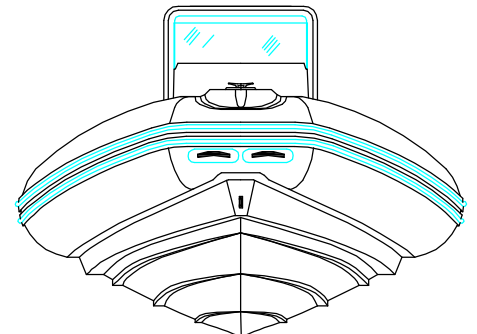

FORE VIEW  
VISTA FRONTAL

MAIN PARTICULARS

MAXIMUM LENGTH/ESLORA MAX. \_\_\_\_\_ 27' 4" (8.33m)  
 MAXIMUM BEAM/MANGA MAX. \_\_\_\_\_ 10' 1" (3.07m)

NOTES: 1. ALL DIMENSIONS IN INCHES  
 TODAS LAS MEDIDAS ESTAN DADAS EN PULGADAS

SUBJECTED: <b>ALEXANDER BARRIOS</b>		<b>TITLE:</b> <b>"OCEANUS 28 VST "</b> <b>GENERAL ARRANGEMENT</b> <b>ARREGLO GENERAL</b>						
APPROVED: <b>HERMES GARCIA</b>		SCALE:	SHEET: <b>1/1</b>	CODE:	PLAN: <b>ARTIGI.28 VST</b>	No.REV <b>2</b>	DATE <b>23.08.12</b>	DRAWN <b>HECTOR SUAREZ</b>
							DATE	APPROVED: